

# The Queens at Selborne

This drawing is copyright and is not to be reproduced. The contractor will be held responsible for the accuracy of works involving the setting out and checking of all dimensions on the drawing and on site. Dimensions must not be scaled from this drawing.



**01 North West Elevation**

Existing low quality extension replaced with new.

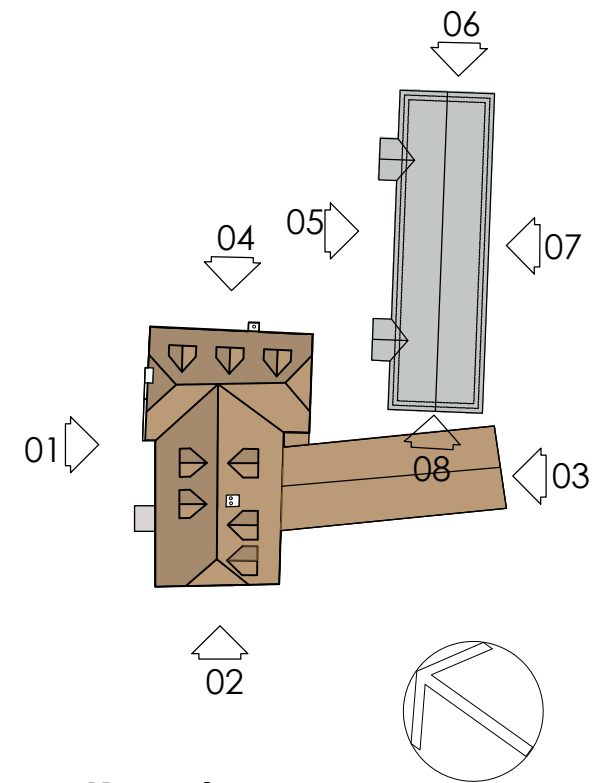

## Key plan Planning

Rev b - 15/12/2020 - side extension removed, single storey retained, new single storey block added to rear

21.05.20 - rev A - existing building amended

REVISIONS:

**barclay+phillips**  
architects

a: The Studio, 5 Oakridge Office Park,  
Southampton Road, Salisbury SP5 3HT  
e: enquiries@barclay-phillips.co.uk  
t: +44 (0) 1722 711177

[www.barclay-phillips.co.uk](http://www.barclay-phillips.co.uk)

PROJECT:  
Proposed Re-development of The Queens at Selborne, High Street,  
Selborne, Hampshire, GU34 3JJ

CLIENT:  
Derek Warwick Developments Ltd.

DRAWING TITLE:  
Proposed North West Elevation



SCALE:  
1:100 @ A3

DATE:  
Mar 2018

DRAWING No.  
**P18-014**  
**02-05-001b**

DRAWN BY:  
LA

CHECKED BY: